

Exterior Roof Jack Extension Kits

Installation Instructions

These instructions are primarily intended to assist qualified individuals experienced in the proper installation of heating and/or air conditioning appliances. Some local codes require licensed installation/service personnel for this type of equipment. Read all instructions carefully before starting the installation.

Used to add additional height to rain caps. (As required by Canadian (CSA) installations.) For Canada the following installation codes apply: CSA B139-1976 Installation code for oil burning equipment. CAN/CGA B149.1-M86 Natural Gas code. CAN/CGA B149.2-M86 Propane Gas code.

DESCRIPTION	MODEL NO.	SPEC. NO.
Exterior Extension 16" Length, 4" Flue Pipe Dia.	EE16A-4	901936-
Exterior Extension 16" Length, 5" Flue Pipe Dia.	EE16A-5	901937-
Exterior Extension (430 SS) 16" Length, 5" Flue Pipe Dia.	EE16A-5SS	902510-

The above extensions may be used to extend the following Telescoping Roof Jack Assemblies.

MODEL NUMBER		
FH1323-4, -5	FO2343-4, -5	SHT2745-4, -5
FH2343-4, -5	SO1835-4, -5	SHT4581-4, -5
SH1835-4, -5	SO2447-4	(F,S)AW(T)-1523 (0,2,4) (A,S)
SH2447-4	SO3263-4, -5	(F,S)AW(T)-2135 (0,2,4) (A,S)
SH3263-4, -5	SO4895-4, -5	(F,S)AW(T)-2747 (0,2,4) (A,S)
SH4895-4, -5	SOT2745-4, -5	(F,S)AW(T)-3563 (0,2,4) (A,S)
FO1323-4, -5	SOT4581-4, -5	(F,S)AW(T)-5195 (0,2,4) (A,S)

! WARNING

Be sure appliance is turned off before installing extension kits.

UPPER PIPE EXTENSION KIT
(Consists of 2 pipes 16" long and 6 #10 sheet metal screws)

1. Remove 3 #10 sheet metal screws from base of roof jack assembly and lift assembly off of the pipes. See Figure 1.

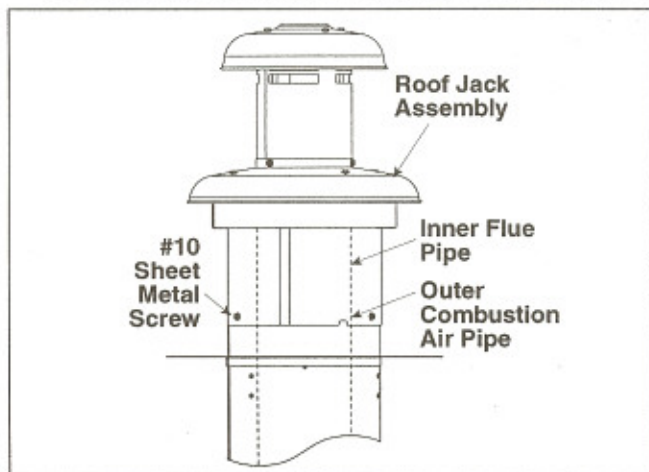

Figure 1.

2. Attach smaller diameter flue pipe to existing flue pipe as shown in Figure 2 by inserting the larger diameter end with stop bead into existing flue and push down to stop. Attach larger diameter outer combustion air pipe onto outer pipe and push downward until pipe seats on stop bead. Secure the outer combustion air pipe in place using the 3 #10 sheet metal screws supplied.

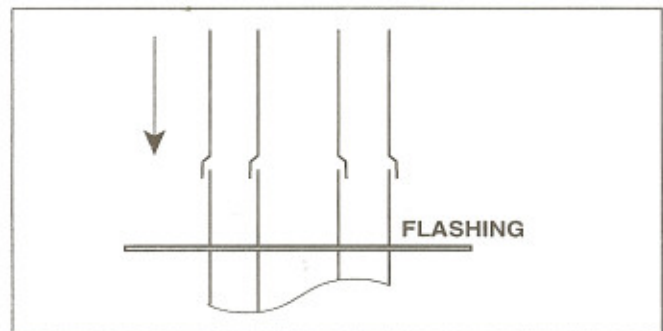

Figure 2.

3. Re-attach previously removed roof jack assembly to newly installed extension pipes. Be sure both pipes slide and seat onto the mating pipes in the roof jack assembly. Secure the roof jack assembly in place onto the outer combustion air pipe as originally installed using 3 #10 sheet metal screws. See Figure 3.

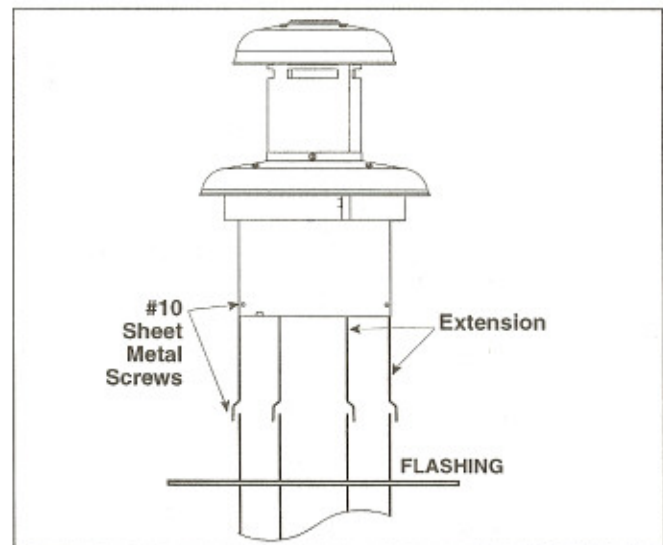

Figure 3.

